

\*48 hours prior to closure  
PCMS #1 & #2

SEE TTC-00(A), TTC-00(B) AND TTC-00(C)

CLOSURE WHEN NO ALTERNATE ROUTE IS AVAILABLE

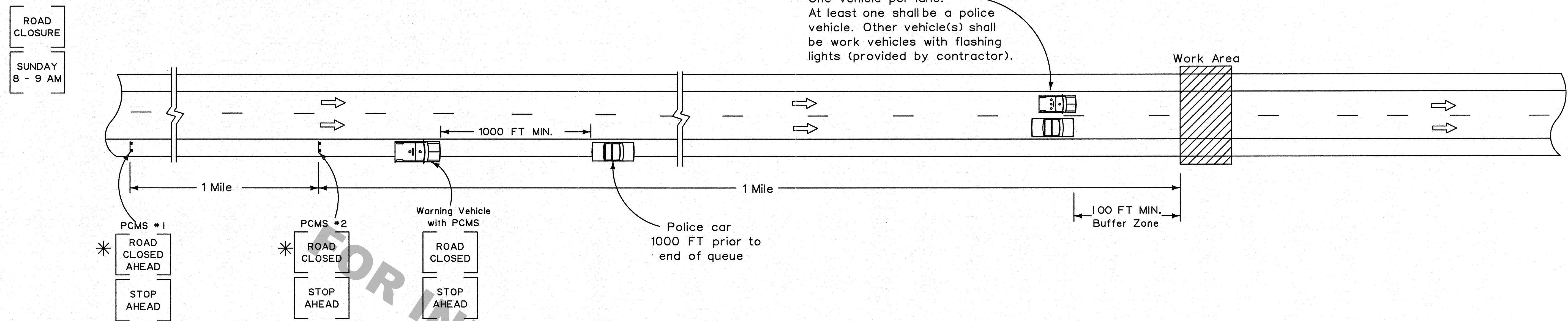

CLOSURE WHEN ALTERNATE ROUTE IS AVAILABLE FROM NEAREST EXIT

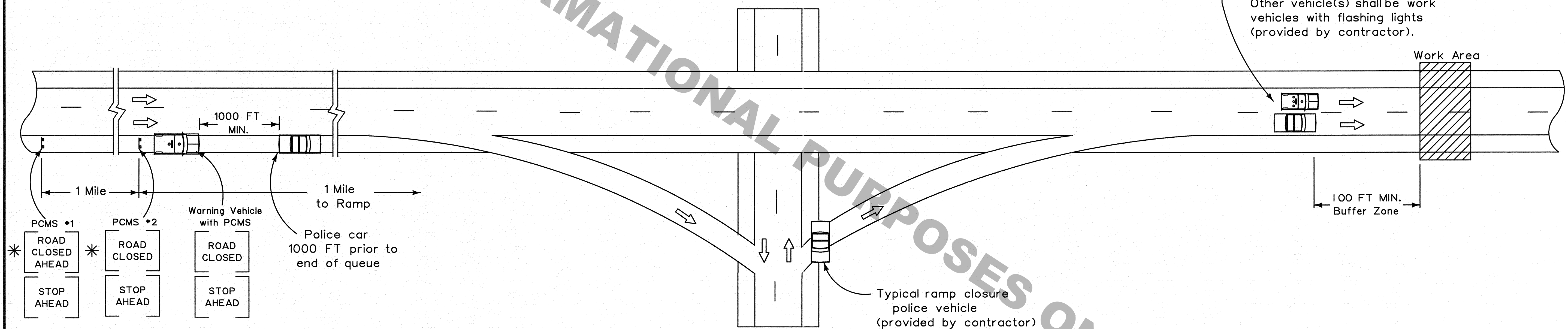

NOTES

This sheet shall be used with the Temporary Traffic Control General Notes Sheets TTC-00(A), TTC-00(B) and TTC-00(C).

1. This layout represents the minimum traffic controls required for short duration closure of divided highways.
2. This type of highway closure shall only be used for emergencies or for construction operations approved by the Engineer and when the duration of closure will not exceed 15 minutes. After the divided highway has been closed and reopened via this procedure a minimum period of 30 minutes or queue dissipation shall elapse before another short duration closure, except with the approval of the Engineer.

3. A minimum of two police officers and two police cars shall be provided on each approach to the closure. Each police car shall have a roof mounted rotation blue light or blue bar.
4. All workers involved in the closure shall maintain radio communications at all times.

ALL TTC STANDARDS SHOW MINIMUM CONSTRUCTION SIGNING.  
ALL SITUATIONS SHALL BE REVIEWED AND/OR DESIGNED BY THE ENGINEER.  
CONTRACTORS ARE RESPONSIBLE FOR COMPLYING WITH ALL TTC STANDARDS.

LEGEND

- ⇒ Direction of Travel
- Police Car
- Work Vehicle with Amber Light
- Warning Vehicle with PCMS

SHEET NUMBER	PARISH	FEDERAL PROJECT	STATE PROJECT
DESIGNED BY: COLVIN	CHECKED BY: ALLAIN	DATE: 02/13/2013	SHEET
DATE: 3-12-13	REVISION DESCRIPTION	BY	DATE
APPROVED BY CHIEF ENGINEER: <i>Paul J. Brown</i>			
TEMPORARY TRAFFIC CONTROL FOR SHORT DURATION CLOSING OF DIVIDED HIGHWAYS			
TTC-15			
TRAFFIC ENGINEERING			