

GENERAL NOTES

DESIGN SPECIFICATIONS: AASHTO LRFD BRIDGE DESIGN SPECIFICATIONS, 6th EDITION 2012, WITH 2013 INTERIMS.

CONCRETE IN PILE: THE CONTRACTOR SHALL DESIGN AND SUBMIT FOR APPROVAL A "PI" CONCRETE MIX WITH A MINIMUM COMPRESSIVE CYLINDER STRENGTH OF 6000 PSI AT 28 DAYS. CONCRETE STRENGTH AT THE TIME OF TRANSFER OF PRESTRESSED FORCE SHALL BE 4500 PSI OR GREATER.

CONCRETE IN BUILD-UP: BUILD-UP CONCRETE SHALL MEET OR EXCEED THE CONCRETE DESIGN REQUIREMENTS OF THE ORIGINAL PILE. BUILT UP CONCRETE NOT MEETING THE ABOVE REQUIREMENTS SHALL BE REMOVED AND REPLACED AT NO DIRECT PAY.

PRESTRESSING STEEL: PRETENSIONED REINFORCEMENT SHALL BE 1/2" DIA. SEVEN-WIRE, UNCOATED LOW-RELAXATION STRANDS GRADE 270 AND SHALL CONFORM TO THE REQUIREMENTS OF AASHTO M203. AN INITIAL TENSION OF 30,980 LBS. SHALL BE APPLIED TO EACH STRAND.

DEFORMED REINFORCING STEEL: REINFORCING STEEL SHALL BE DEFORMED STEEL BARS, GRADE 60 AND SHALL MEET THE REQUIREMENTS OF AASHTO M31.

SPIRAL REINFORCING STEEL: SPIRAL REINFORCEMENT SHALL BE SIZE W-4.5 COLD-DRAWN STEEL WIRE AND SHALL CONFORM TO AASHTO M 32M.

FABRICATION: MANUFACTURE OF THE PILING AND FABRICATION TOLERANCES SHALL BE IN ACCORDANCE WITH THE "MANUAL FOR QUALITY CONTROL FOR PLANTS AND PRODUCTION OF STRUCTURAL PRECAST CONCRETE PRODUCTS (MNL-116, LATEST EDITION) PUBLISHED BY PCI, AND THE DRAFT DETAIL SHOWN BELOW.

CHAMFERS AND CORNERS: ON PILES 18" Ø OR SMALLER, ALL EXPOSED CONCRETE CORNERS ARE TO HAVE 3/4" CHAMFERS. ON PILES 20" Ø OR LARGER, ALL EXPOSED CONCRETE CORNERS ARE TO HAVE 1/2" CHAMFERS. A 1" RADIUS CURVE WILL BE PERMITTED IN LIEU OF CHAMFERS SHOWN ABOVE. HOWEVER, ALL PILES FURNISHED SHALL BE OF THE SAME CONFIGURATION.

PICK-UP AND HANDLING: LOADING CRITERIA ARE BASED ON CAREFUL HANDLING OF THE PILE. ROTATION OF THE PILE IN THE SLING SHALL BE PREVENTED UNTIL THE PILE IS IN VERTICAL POSITION.

PICK-UP POINTS FOR ALL THE PILES SHALL BE CLEARLY MARKED ON PILES. SUPPORT FOR STORAGE SHALL BE AT PICK-UP POINTS. IN THE CASE OF 1-POINT PICK-UP, SUPPORT PILE AT 0.29L₁ FROM EACH END.

PILES SHALL BE MADE AT A CENTRAL PLANT AND BE TRANSPORTED TO THE BRIDGE SITE. BEFORE TRANSPORTATION, ALL PRESTRESSED PILING SHALL BE HELD AT THE PLANT FOR 14 DAYS AFTER CASTING AND SHALL ATTAIN A MINIMUM COMPRESSIVE STRENGTH OF 6000 PSI.

PICK-UP POINTS SHOWN MAY BE MODIFIED FOR TRANSPORTATION PURPOSES, PROVIDED THE PILE STRESSES ARE IN ACCORDANCE WITH THE DESIGN CRITERIA. ANY SUPPORT CONFIGURATION DIFFERING FROM THOSE SHOWN ON THIS PLAN SHALL REQUIRE STAMPED AND SIGNED CALCULATIONS TO BE SENT TO THE BRIDGE DESIGN ENGINEER FOR REVIEW.

PILES REQUIRING THREE PICK-UP POINTS AND TRUCK TRANSPORTATION SHALL REQUIRE PIVOTING SPREADER BEAMS THAT PROVIDE FOUR POINTS OF SUPPORT TO THE PILE, RESULTING IN PILE STRESSES WITHIN DESIGN CRITERIA. THE TRUCK TRANSPORT SUPPORT POINTS SHALL BE SENT TO THE BRIDGE DESIGN ENGINEER FOR REVIEW.

ALL EMBEDDED LIFTING LOOPS SHALL BE PROVIDED WITH 2" DEEP FOAM BLOCK-OUTS. PRIOR TO TRANSPORT, LIFTING LOOPS SHALL BE REMOVED TO PROVIDE 2" MINIMUM CLEAR COVER. THE REMAINING CAVITIES SHALL BE CLEAR OF ALL SLAG AND LOOSE MATERIAL, AND THEN FILLED WITH A PATCHING MATERIAL FROM QPL NO. 49. THE PATCHING MATERIAL MUST MEET OR EXCEED PILE CONCRETE REQUIREMENTS FOR STRENGTH AND PERMEABILITY.

VENT HOLES: FOR VOIDED PILES THAT REQUIRE BUILD-UP OR CUT-OFF, THE VENT HOLES SHALL BE RE-ESTABLISHED AT 6" BELOW THE BOTTOM OF THE BENT CAP, AS SHOWN IN THE "CUT OFF" AND "BUILD-UP" PILE DETAILS ON THIS PLAN.

SHOP DRAWINGS: ANY DEVIATION FROM THE DETAILS SHOWN ON THIS SHEET, OR ANY DESIGN CHANGES MADE TO THE PILES SHALL REQUIRE SHOP DRAWINGS TO BE SUBMITTED TO THE BRIDGE DESIGN ENGINEER FOR REVIEW AND APPROVAL PRIOR TO FABRICATION.

ALLOWABLE HANDLING STRESSES: THE MAXIMUM LENGTHS FOR PICK-UP HAVE BEEN DETERMINED USING THE FOLLOWING AASHTO LRFD STRESSES FOR BOTH 14 AND 90 DAYS.

CONTROL OF CRACKS IN CONCRETE: VOIDS SHALL TERMINATE NOT LESS THAN 12 INCHES BEYOND THE LONGEST PILE SPLICE REBAR EXTENSION.

MOMENT CONNECTIONS: WHENEVER METAL PIPE IS USED TO FORM A MOMENT CONNECTION THE SPIRAL SPACING (2") SHALL EXTEND THE FULL LENGTH OF AND AT LEAST 18 INCHES BEYOND THE END OF THE PILE.

ALLOWABLE TENSILE STRESS (ksi): $0.19 \sqrt{f'_c}$
ALLOWABLE COMPRESSIVE STRESS (ksi): $0.45 f'_c$
IMPACT FACTOR: 1.5
MIN. FINAL COMPRESSIVE STRESS: 0.7 ksi

PILE INFORMATION

PILE SIZE (in.)	SECTION PROPERTIES					SQUARE SPIRAL LAYOUTS					
	VOID "D" (in.)	AREA (in. ²)	SECTION MODULUS (in. ³)	WEIGHT PER FOOT (lb/ft)	CHAMFER (in.)	NO. OF STRANDS	PRESTRESS IN CONCRETE (psi)		MAX. CASTING LENGTH (ft)		
							AT RELEASE	AT 90 DAYS	L ₁	L ₂	L ₃
12 SOLID	-	144	288	150	3/4"	4	830	774	53.3	76.0	105.0
14 SOLID	-	196	457	204	3/4"	8	1203	1116	66.0	93.4	130.4
16 SOLID	-	256	683	267	3/4"	12	1373	1273	67.6	95.7	136.7
18 SOLID	-	324	972	338	3/4"	12	1096	1026	72.0	102.7	142.5
20 SOLID	-	400	1333	417	1/2"	16	1180	1106	78.4	111.3	154.6
24 SOLID	-	576	2304	600	1/2"	24	1227	1154	86.7	122.7	172.0
24 VOIDED	10.5	489	2254	510	1/2"	20	1204	1119	92.9	131.4	183.2
30 VOIDED	16.5	686	4257	715	1/2"	28	1203	1120	107.8	152.6	212.5
36 VOIDED	22.5	898	7077	936	1/2"	36	1182	1102	120.6	170.9	237.9

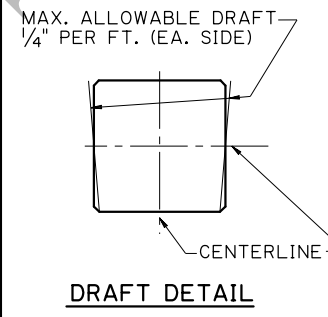

SHEET NUMBER

PARISH

CONTROL SECTION

STATE PROJECT

DESIGN CHECK: A. LANCASTER, K. KEMP

DETAIL CHECK: A. WILLIAMS, W. PENG

REVIEW: K. KEMP

SERIES: 1 OF 1

APPROVED BY CHIEF ENGINEER: [Signature]

DATE: 11/26/2025

REVISION OR CHANGE ORDER DESCRIPTION

NO.

DATE

BY

STATE OF LOUISIANA

PRE-CAST PRESTRESSED CONCRETE PILES

PPC PILES CS-216

DOTD
 LOUISIANA DEPARTMENT OF TRANSPORTATION & DEVELOPMENT

STANDARD PLAN